

WHELEN[®]

ENGINEERING COMPANY

51 Winthrop Road,
Chester, Connecticut 06412-0684
Phone: (860) 526-9504

Installation Guide: WeCanX™ V2V Sync Module

Internet: www.whelen.com
Sales e-mail: autosale@whelen.com
Customer Service e-mail: custserv@whelen.com

⚠ WARNING: This product can expose you to chemicals including Lead which is known to the State of California to cause cancer and birth defects or other reproductive harm. For more information go to www.P65Warnings.ca.gov.

Mounting the V2V Module

IMPORTANT: Module must be mounted inside the vehicle in a location not exposed to excessive heat or weather.

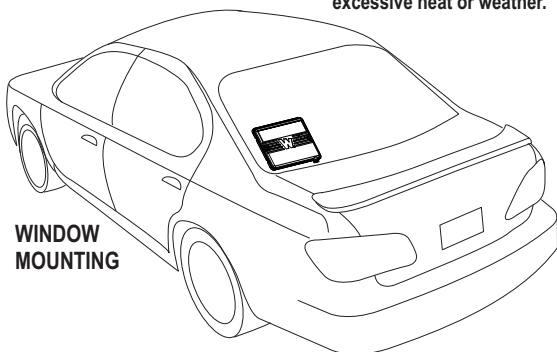

Mounting to Vehicle:

It is recommended you mount the module to the dashboard or rear deck of the vehicle however it can be mounted to any surface or window. If mounted to a window it is recommended to use VELCRO® hook & loop tape. The module must be mounted face up (side with logo). This is the side that receives the signal. If mounted to a window, the face must point out of the vehicle.

©2020 Whelen Engineering Company Inc.
Form No.14D18B (061121)

Mounting to Dash, Rear Deck or other surface:

IMPORTANT!

It is the responsibility of the installation technician to make sure the installation and operation of this product will not interfere with or compromise the operation or efficiency of any other vehicle equipment!

Before returning the vehicle to active service, visually confirm the proper operation of this product, as well as all vehicle components or equipment.

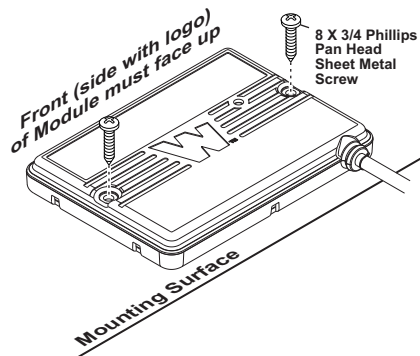

For warranty information regarding this product, visit www.whelen.com/warranty

WHELEN[®]

ENGINEERING COMPANY

51 Winthrop Road,
Chester, Connecticut 06412-0684
Phone: (860) 526-9504

Installation Guide: WeCanX™ V2V Sync Module

Internet: www.whelen.com
Sales e-mail: autosale@whelen.com
Customer Service e-mail: custserv@whelen.com

⚠ WARNING: This product can expose you to chemicals including Lead which is known to the State of California to cause cancer and birth defects or other reproductive harm. For more information go to www.P65Warnings.ca.gov.

Mounting the V2V Module

IMPORTANT: Module must be mounted inside the vehicle in a location not exposed to excessive heat or weather.

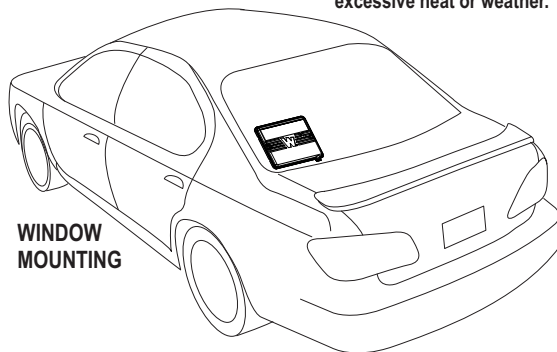

Mounting to Vehicle:

It is recommended you mount the module to the dashboard or rear deck of the vehicle however it can be mounted to any surface or window. If mounted to a window it is recommended to use VELCRO® hook & loop tape. The module must be mounted face up (side with logo). This is the side that receives the signal. If mounted to a window, the face must point out of the vehicle.

©2020 Whelen Engineering Company Inc.
Form No.14D18B (061121)

Mounting to Dash, Rear Deck or other surface:

IMPORTANT!

It is the responsibility of the installation technician to make sure the installation and operation of this product will not interfere with or compromise the operation or efficiency of any other vehicle equipment!

Before returning the vehicle to active service, visually confirm the proper operation of this product, as well as all vehicle components or equipment.

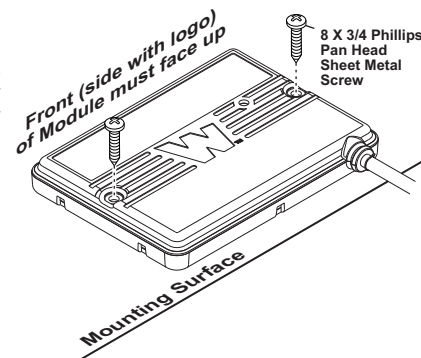

For warranty information regarding this product, visit www.whelen.com/warranty

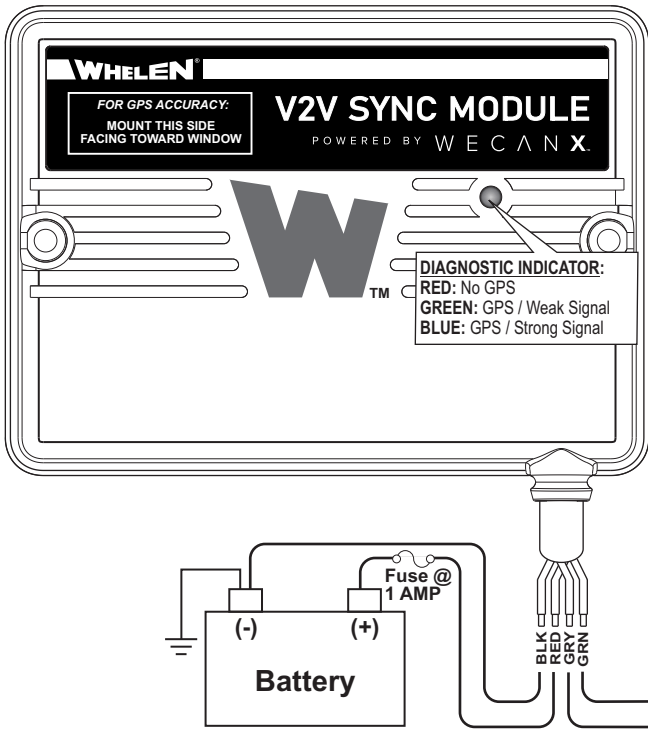

V2V Sync Module:

Wire as shown installing a customer supplied fuse into the power wire. Plug the connector into J18 of Core Main Box and operate using the Core system.

Specifications:

Input Voltage: +12 VDC
Current Draw: 30 mA

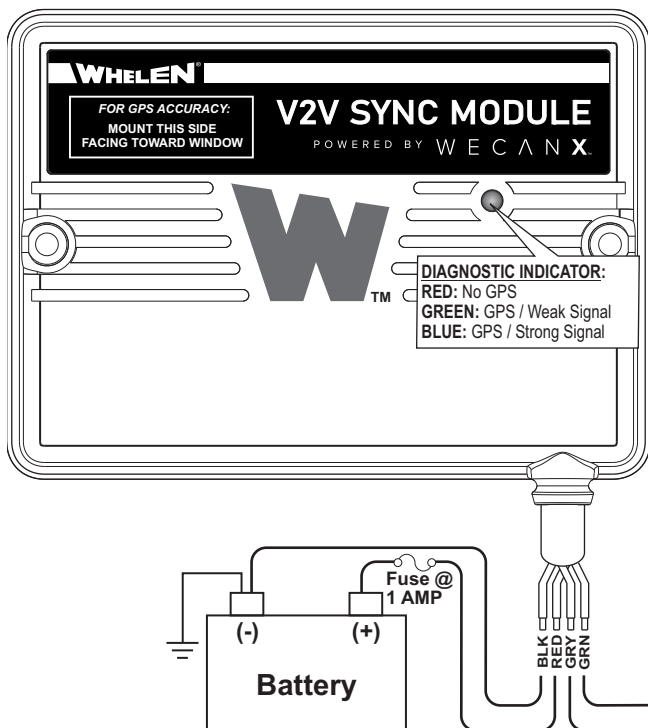
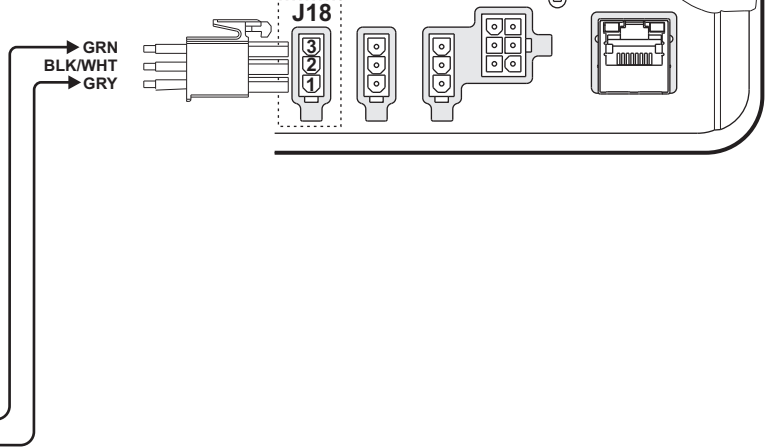

V2V Sync Module:

Wire as shown installing a customer supplied fuse into the power wire. Plug the connector into J18 of Core Main Box and operate using the Core system.

Specifications:

Input Voltage: +12 VDC
Current Draw: 30 mA

